



創唯實業有限公司

PLASTRONIC TECHNOLOGY CO., LTD.

TEL : 886-2-2276-3375

www.loadcell.com.tw

E-mail: plastronictech@gmail.com

FAX : 886-2-2276-3557

www.plastronic.com.tw

新北市24252新莊區化成路398巷13號

No.13, Lane 398, Huacheng Rd., Xinzhuang Dist., New Taipei City 24252, Taiwan

## DC12

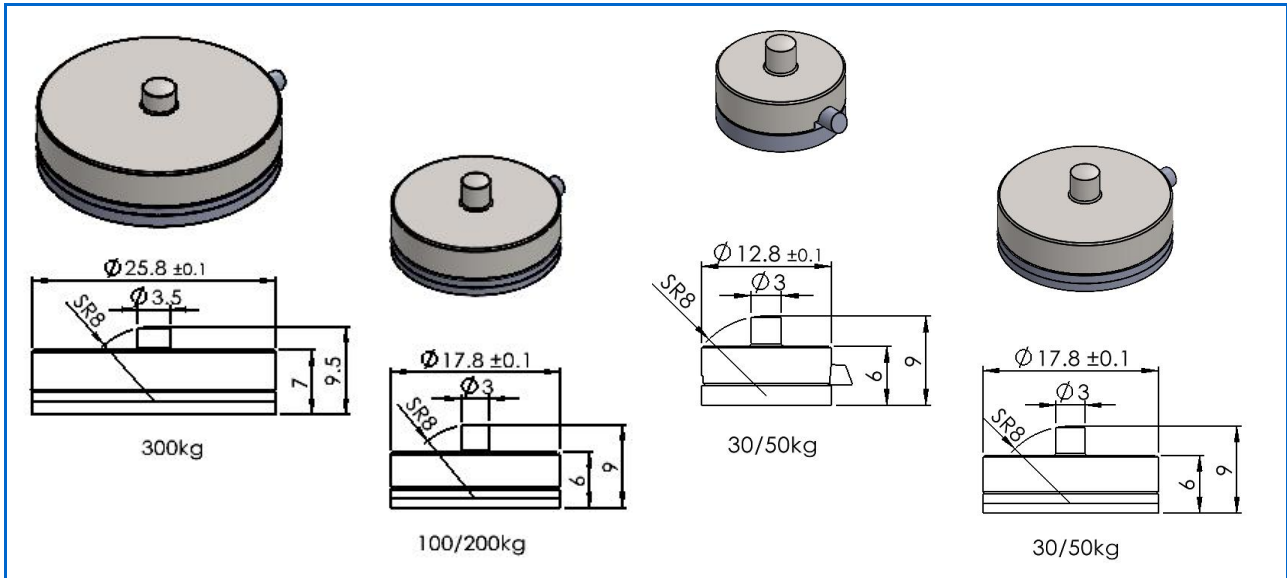

應用：下壓力量測/控制系統

Applications: Batching scale, industrial weighing/control system

### 技術規格 Specification

額定荷重	Rated Capacities	30,50,100,200,300 kg
額定輸出	Rated Output	2.0 mV/V±20%
精度等級	Accuracy class	
非線性	Non-linearity	0.3%F.S
遲滯	Hysteresis	
重複性	Repeatability	0.1%F.S
蠕變/回零(4分鐘)	4mins Creep/DR	
輸出溫度影響	Temperature Effect On Output	0.3 %F.S/10°C
零點溫度影響	Temperature Effect On Zero	0.3 %F.S/10°C
零點平衡	Zero Balance	±0.300 mV/V
輸入阻抗	Input Impedance	1000±50 Ω
輸出阻抗	Output Impedance	1000±50 Ω
絕緣阻抗	Insulation Impedance	≥2000 MΩ/50 VDC
安全過載率	Safe Overload	120 %F.S
極限過載率	Ultimate Overload	
工作溫度範圍	Operating Temperature Range	-20~60 °C
建議工作電壓	Recommended Excitation	≤10 VDC
最大工作電壓	Maximum Excitation	
材質	Construction	不鏽鋼 Stainless steel
防水等級	Protection Class	IP65
電纜線	Cable	φ2×2m
建議台面尺寸	Recommended Platform Size	

接線方式 Mode of Connection

紅：電源+，黑：電源-，綠：信號+，白：信號-  
Red (EXC+) ,Black (EXC-) ,Green (SIG+) ,White (SIG-)